



SP001G

XGT Cordless Plunge Cut Saw (165mm)
Powered by 40V MAX Lithium-Ion Battery

High power for fast cutting and ripping

The combination of XGT battery and brushless motor provides 2,500 - 4,900 RPM for continuous operation in heavy-duty applications.



180cuts (with 5.0Ah XGT battery) High Cutting Efficiency

Material: 40 x 600mm Kitchen board (Laminated wood) cutting, Bevel angle: 0°
The test results depends on the hardness of the test material, etc.



Can be attached to the guide rail without an adapter



Max Cutting Capacity **56 mm**

Constant speed control
Provides consistent surface finish.

Rotatable dust nozzle
Added two leaf springs enable to twist and lock the nozzle with a click in order to reduce unexpected rotation.

Electric brake system
Enables you to start the next operation quickly.

Soft start
Feature for smooth start-ups.

Extreme Protection Technology
Integrated seals designed to improve a tool's operation in harsh conditions by channeling water and dust from key internal components.

Variable speed control by dial
An optimum cutting speed can be selected to suit application.



Using magnesium diecast base plate
Tool weight has been reduced without loss of durability and power.

Auto-start Wireless System
Automatically activates compatible AWS vacuum once the trigger switch is engaged. Paired extraction unit will operate when the saw is in operation and shut down once the trigger is released.

Note: Wireless unit is required to activate the Bluetooth Part #: 198900-7 (Optional).



Bevel cut

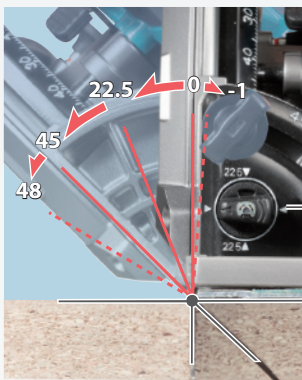

Bevel range
:-1 to 48 degrees

Positive stopper

Precision bevel cut
The position of cutting line is always the same regardless of bevel angle in cutting with Guide Rail attached.

Depth stopper for splinter-free cutting

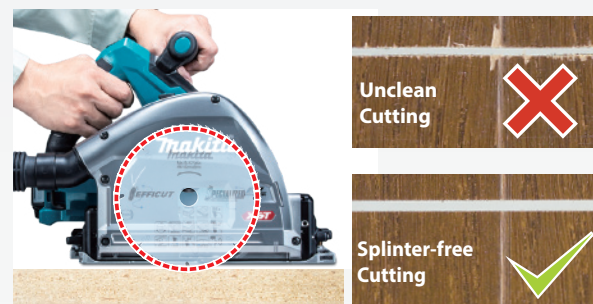

Enables to easily cut a preliminary groove at a depth of 2mm (1/16") for splinter-free cuts.

Specification

Blade Diameter	165 mm
Bore Diameter	20 mm
Max Cutting Capacity	90°: 56 mm 45°: 40 mm 48°: 38mm
No Load Speed (RPM)	2,500 - 4,900
Vibration Level	2.5 m/s ² or less
Sound Pressure / Power	89 dB(A) / 100 dB(A)
Dimensions (L x W x H)	347x221x271mm (without battery)
Net weight	3.7 kg (without battery)

Available Variants

VARIANTS	MODELS	AWS CHIP	BATTERY	CHARGER	CASE
BARE TOOL	SP001G Z02	-	-	-	YES

Accessories: Plunge Cut Saw Blades (Optional)

Blade Dia (mm)	(Bore) Hole dia. (mm)	(Kerf) Tip Thickness (mm)	Plate (mm)	Angle	No. of teeth	Tooth Shape	Application	Part No.
165	20	1.4	1	23	56	ATAFR	Wood/MDF	B-57364 EFFICUT
165	20	1.85	1.25	8	48	ATB	Wood	B-56166
165	20	2.2	1.6	8	48	ATB	Wood	B-09298
165	20	2.0	1.4	5	60	TCG	MDF	B-56677
165	20	2.0	1.4	-3	56	TCG	Aluminium	B-56655
165	20	2.4	1.7	-3	56	TCG	Aluminium	B-09307
165	20	2.0	1.4	5	48	TCG	CORIAN®	B-56683

Other Optional Accessories

Guide rail
1.4M - 194368-5
3M - 194367-7

Guide rail holder
1.4M - B-57613
1.4M - E-05664

Guide rail joint connector 2pcs set
198885-7

Splinter guide for Guide rail
423360-7

Clamp set
(use with Guide rail)
Type A. 194385-5
Type B. 199826-6

Bevel guide
196664-7

Guide rule
165447-6

Dust bag
126599-8



MAKITA GULF FZE

www.makita.ae |